

## Technical Data Sheet

# AMIK 300 / 301



**AMIK 300** is a compact multifunction instrument with touch screen LCD utility which measures important electrical parameters in 3 phase and single phase System & replaces the need of multiple analog panel meters.

### Special Features

- True RMS Measurement
- Onsite Programmable
- Low Back Depth
- Phase Reversal Indication
- Touch screen graphics LCD
- RS-485 MODBUS & 4-20 mA analog output, included on Model 301.

## Application

**AMIK 300** measures important electrical parameters in 3 phase and single phase System & replaces the need of multiple analog panel meters. It measures electrical parameters like AC current, Voltage, frequency, active energy import & active energy export, Current Demand, kW Demand, kVA Demand and Max Current Demand, Max kW Demand and Max kVA Demand.

## Product Features

<b>Touch screen graphics LCD</b>	AMIK 300 has touch sensible color graphics LCD display with resolution of 320 x 240.	<b>Phaser Diagram</b>	Pictorial representation of all 3 Phases (Voltage & Current) in terms of vectors.
<b>On site programmable PT/CT ratios</b>	It is possible to program primary of external Potential Transformer (PT), primary of external Current Transformer (CT) on site locally by entering into Programming mode or remotely via MODBUS (RS-485)	<b>Wave Form</b>	Pictorial representation of all 3 phases Current & voltage in terms of sinusoidal waveform.
<b>User selectable CT Secondary 5A/1A</b>	The secondary of external Current Transformer (CT) can be programmed on site to either 5A or 1A locally by entering into Programming mode or remotely via MODBUS (RS-485)	<b>Total Harmonic Distortion (THD)</b>	The instrument can measures per phase (%) THD of voltage and (%) THD of current.
<b>User selectable PT Secondary</b>	The secondary of external Potential Transformer (PT) can be programmed on site locally by entering into Programming mode or remotely via MODBUS (RS-485)	<b>Energy Count storage</b>	In case of power failure, the instrument memorizes the last energy count. Every 40 sec, the instrument updates the energy counter in the nonvolatile memory.
<b>User selectable 3 phase 3W or 4W unbalanced system</b>	User can program on site the system connection as either 3 Phase 3 Wire or 4 Wire locally by entering into Programming mode or remotely via MODBUS (RS-485). For single phase applications, single phase version is available.	<b>Programmable Energy format &amp; Energy rollover count</b>	Customer can assign the format for energy display on MODBUS (RS-485) in terms of W, kW or MW. Additional to this, customer can also set a rollover count from 7 to 14 digits depending on the energy format.
<b>Low back depth</b>	The instrument has very low back depth (behind the panel) of less than 80 mm in spite of optional features like pulse output	<b>Hour Run, ON Hour, Number of Interruptions</b>	Hour run records the number of hours load is connected. ON Hour is the period for which the auxiliary supply is ON. Number of Interruptions indicates the number of times the Auxiliary Supply was interrupted.
<b>Onsite selection of Auto scroll / Fixed Screen</b>	User can set the display in auto scrolling mode or fixed screen mode can be programmed locally by entering into Programming mode or remotely via MODBUS (RS485).	<b>Optional MODBUS (RS485) Output</b>	The optional ModBus output enables the instrument to transmit all the measured parameters over standard MODBUS (RS-485).
<b>Phase reversal indication</b>	The instrument can detect wrong phase sequence or failure of one of the input voltages and displays "phase" error message.	<b>User Assignable Registers for MODBUS</b>	Customer can assign MODBUS register address as per his need for faster response time.
<b>Energy measurement (Import and Export)</b>	Active energy (kWh), Reactive energy (kVarh), Apparent energy (kVAh) & Ampere Hour (kAh). Any of the parameters can be freely assigned to 2 optional pulse outputs.		
<b>True RMS measurement</b>	The instrument measures distorted waveform up to 15th Harmonic.		
<b>User selectable Low Current suppression (below 30 mA)</b>	User can suppress the readings below 30 mA in the current measurement by onsite programming if required.	<b>Configuration of the Instrument via MODBUS</b>	The instrument settings can be configured locally by entering into Programming mode or remotely via MODBUS (RS485) <b>Note:</b> The MODBUS communication parameters can only be set locally by entering into the Programming mode.

## Product Features

<b>Min Max storage of parameters possible</b>	The instrument stores minimum and maximum values for System Voltage and System Current. Every 40 sec minimum and maximum readings are updated.
<b>Number of parameters measured : more than 46</b>	The instrument measures more than 46 electrical parameters of 3 Phase network.
<b>Parameter Screen recall</b>	In case of power failure, the instrument memorizes the last displayed screen. The displayed screen will get memorized only if user keeps this screen for minimum 40 sec duration before power failure for fixed screen mode.

<b>Optional Analog Outputs (1 or 2 Outputs)</b>	1 or 2 Analog outputs can be programmed from a list of input parameters.
<b>Enclosure Protection for dust and water</b>	conforms to IP 54 (front face) as per IEC60529
<b>Compliance to International Safety standards</b>	Compliance to International Safety standard IEC 61010-1- 2001
<b>EMC Compatibility</b>	Compliance to International standard IEC 61326

## Technical Specifications

Reference conditions for Accuracy	
Reference temperature	23°C +/- 2°C
Input waveform	Sinusoidal (distortion factor 0.005)
Input frequency	50 or 60 Hz ±2%
Auxiliary supply voltage	Rated Value ±1%
Auxiliary supply frequency	Rated Value ±1%
Voltage Range	50... 100% of Nominal Value. 60... 100% of Nominal Value for THD.
Current Range	10... 100% of Nominal Value. 20... 100% of Nominal Value for THD.
Power	Cos phi / sin phi = 1 for Active / Reactive Power & Energy. 10... 100% of Nominal Current & 50... 100% of Nominal Voltage.
Power Factor / Phase Angle	40... 100% of Nominal Current & 50... 100% of Nominal Voltage.

Accuracy	
Voltage	± 0.5% of range
Current	± 0.5% of range
Frequency	± 0.15% of mid frequency
Active Power	± 0.5% of range
Re-Active Power	± 0.5% of range
Apparent Power	± 0.5% of range
Active energy (kWh)	± 0.5% of range
Re Active energy (kVArh)	± 0.5% of range
Apparent energy (kVAh)	± 0.5% of range
Accuracy of Analog Output	1 % of Output end value
Power Factor	±1% of Unity
Angle	±1% of range
Total Harmonic Distortion	±1%

## Electrical Connections

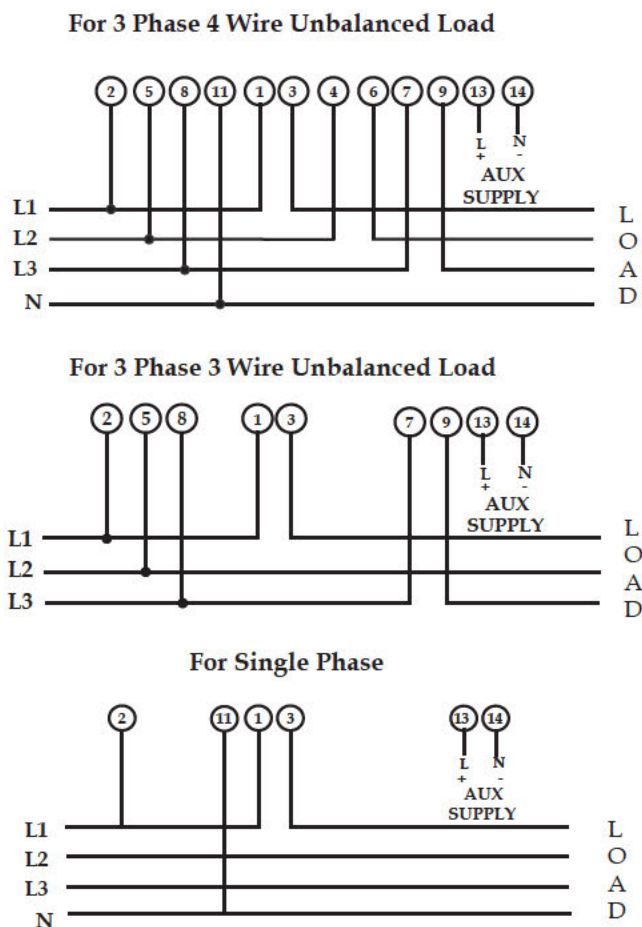

It is recommended that the wires used for connections to the instrument should have lugs soldered at the end. That is, the connections should be made with Lugged wires for secure connections. The Maximum diameter of the lug should be 7.0 mm and maximum thickness 3.5 mm. Permissible cross section of the connection wires: <= 4.0 mm<sup>2</sup> single wire or 2 × 2.5 mm<sup>2</sup> fine wire.

## Technical Specifications

### Input Voltage

Nominal input voltage (AC RMS)	Phase -Neutral 63.5 / 133 / 239.6 / 254 VL-N Line-Line 110/230/415/ 440 VL-L
System PT primary values	100VLL to 692kVLL programmable on site.
Max continuous input voltage	120% of rated value

### Input Current

Nominal input current	5A AC RMS.
System CT secondary values	1A & 5A programmable on site.
System CT primary values	From 1A up to 9999A (for 1 or 5 Amp )
Max continuous input current	120% of rated value

### Auxiliary Supply

AC/DC Auxiliary Supply	100V... 250 VAC DC +/- 10%
DC Auxiliary Supply	12.....48 VDC +/- 10%
AC Auxiliary supply frequency range	45 to 66 Hz

### Overload Withstand

Voltage	2 x rated value for 1 second, repeated 10 times at 10 second intervals
Current	20x rated value for 1 second, repeated 5 times at 5 min

### Operating Measuring Ranges

Voltage	5... 120% of rated value
Current	5 ... 120% of rated value
Frequency	40...70 Hz
Power Factor	0.5 Lag ... 1... 0.8 Lead

### Influence of Variations

Temperature coefficient	0.025%/°C for Voltage (50... 120% of rated value) and 0.05%/°C for Current (10... 120% of rated value)
-------------------------	---

### Environmental

Operating temperature	-20 to +70°C
Storage temperature	-30 to +80°C
Relative humidity	0... 95% non condensing
Warm up time	Minimum 3 minute
Shock	15g in 3 planes
Vibration	10... 55 Hz, 0.15mm amplitude

## Dimensions

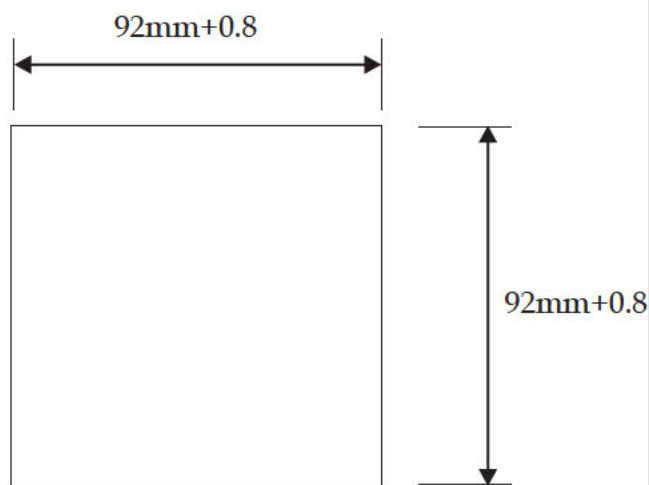
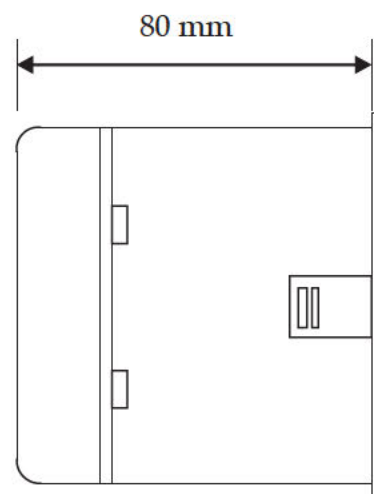
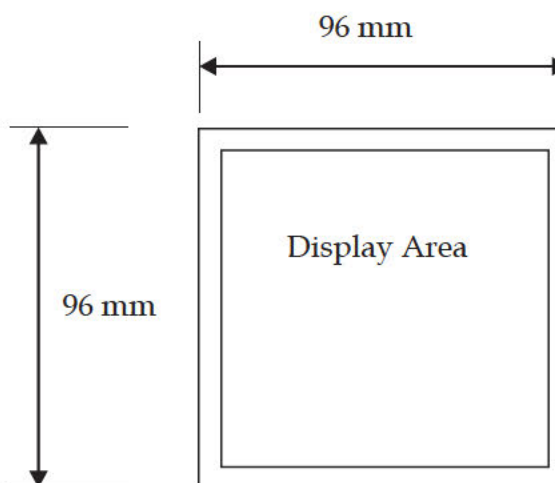

Panel Cutout

## Technical Specifications

Display update rate	
Response time to step input	1 sec approx.
Applicable Standards	
EMC	IEC 61326
Immunity	IEC 61000-4-3. 10V/m min - Level 3 industrial low level
Safety	IEC 61010-1-2001 , Permanently connected use
IP for water & dust	IEC60529
Pollution degree	2
Installation category	III
High Voltage Test	2.2 kV AC, 50Hz for 1 minute between all electrical circuits
VA Burden	
Nominal input voltage burden	< 0.2 VA approx. per phase
Nominal input current burden	< 0.6 VA approx. per phase
Auxillary Supply burden	
For VAC Aux.	< 6.5 VA approx.
For DC Aux.	< 3 W approx.

## PT Secondary Ranges for Various Input Voltage

Input Voltage	PT Secondary Settable Range
110V L-L (63.5V L-N)	100V - 120V L-L (57V - 69V L-N)
230V L-L (133V L-N)	121V - 239V L-L (70V - 139V L-N)
415V L-L (239.6V L-N)	240V - 480V L-L (140V - 277V L-N)

## Ampere Hour

Default pulse rate divisor	CT secondary = 1A Max pulse rate 3600 pulses/Ah *  CT secondary = 5A Max pulse rate 720 pulses/Ah
Other Pulse rate Divisors (applicable only when Energy on MODBUS (RS-485) is in W)	
10	CT secondary = 1A Max pulse rate 3600 pulses/10Ah *  CT secondary = 5A Max pulse rate 720 pulses/10Ah
100	CT secondary = 1A Max pulse rate 3600 pulses/100Ah *  CT secondary = 5A Max pulse rate 720 pulses/100Ah
1000	CT secondary = 1A Max pulse rate 3600 pulses/1000Ah *  CT secondary = 5A Max pulse rate 720 pulses/1000Ah
Pulse duration	60 ms, 100 ms or 200 ms
<p>*No. of Pulses = <math>\frac{\text{Maximum Pulses}}{\text{CT Ratio}}</math> Where, CT Ratio = (CT primary/ CT Secondary)</p>	

## Electrical Parameters

Sr No	Displayed Parameters	3 Phase 4Wire	3Phase 3Wire	Single Phase 2W
1.	System Volts	✓	✓	✓
2.	System Current	✓	✓	✓
3.	Volts L1 - N	✓	✗	✗
4.	Volts L2 - N	✓	✗	✗
5.	Volts L3 - N	✓	✗	✗
6.	Volts L1 - L2	✓	✓	✗
7.	Volts L2 - L3	✓	✓	✗
8.	Volts L3 - L1	✓	✓	✗
9.	Current L1	✓	✓	✗
10.	Current L2	✓	✓	✗
11.	Current L3	✓	✓	✗
12.	Neutral Current	✓	✗	✗
13.	Frequency	✓	✓	✓
14.	System Active Power (kW)	✓	✓	✓
15.	Active Power L1 (kW)	✓	✗	✗
16.	Active Power L2 (kW)	✓	✗	✗
17.	Active Power L3 (kW)	✓	✗	✗
18.	System Re-active Power (kVAr)	✓	✓	✓
19.	Re-active Power L1 (kVAr)	✓	✗	✗
20.	Re-active Power L2 (kVAr)	✓	✗	✗
21.	Re-active Power L3 (kVAr)	✓	✗	✗
22.	System Apparent Power (kVA)	✓	✓	✓
23.	Apparent Power L1 (kVA)	✓	✗	✗
24.	Apparent Power L2 (kVA)	✓	✗	✗
25.	Apparent Power L3 (kVA)	✓	✗	✗
26.	System Power Factor	✓	✓	✓
27.	Power Factor L1	✓	✗	✗
28.	Power Factor L2	✓	✗	✗
29.	Power Factor L3	✓	✗	✗
30.	Phase Angle L1	✓	✗	✓
31.	Phase Angle L2	✓	✗	✗
32.	Phase Angle L3	✓	✗	✗
33.	Import kWh (8 digit resolution)	✓	✓	✓
34.	Export kWh (8 digit resolution)	✓	✓	✓
35.	Import kVArh (8 digit resolution)	✓	✓	✓
36.	Export kVArh (8 digit resolution)	✓	✓	✓
37.	kVAh (8 digit resolution)	✓	✓	✓
38.	KAh (8 digit resolution)	✓	✓	✓
39.	Current Demand	✓	✓	✓
40.	KVA Demand	✓	✓	✓
41.	KW Import Demand	✓	✓	✓
42.	KW Export Demand	✓	✓	✓
43.	Max Current Demand	✓	✓	✓
44.	Max KVA Demand	✓	✓	✓
45.	Max KW Import Demand	✓	✓	✓
46.	Max KW Export Demand	✓	✓	✓
47.	Run Hour	✓	✓	✓
48.	On Hour	✓	✓	✓
49.	Number of Interruptions	✓	✓	✓
50.	Phase Reversal Indication	✓	✗	✗
51.	Phaser Diagram (Pictorial Representation)	✓	✗	✓
52.	VA waveform (Pictorial Representation)	✓	✗	✓
53.	THD Volts L1-N	✓	✗	✗

✓ : Available      ✗ : Not Available

## Electrical Parameters

Sr No	Displayed Parameters	3 Phase 4Wire	3Phase 3Wire	Single Phase 2W
54.	THD Volts L2-N	✓	✗	✗
55.	THD Volts L3-N	✓	✗	✗
56.	THD Volts L1-L2	✗	✓	✗
57.	THD Volts L2-L3	✗	✓	✗
58.	THD Volts L3-L1	✗	✓	✗
59.	THD Current L1	✓	✓	✗
60.	THD Current L2	✓	✓	✗
61.	THD Current L3	✓	✓	✗
62.	THD Voltage Mean	✓	✓	✓
63.	THD Current Mean	✓	✓	✓

✓ : Available      ✗ : Not Available

## Ordering Information

Product Code	Amik 300 (Without MODBUS) Amik 301 (With MODBUS)	Catalog No. A300 Catalog No. A301
System Type	3 Ph. (PR. 3W or 4W) 1 Ph.	
Input Voltage	440V L-L	
Input Current	1/5A	
Power Supply	100 V - 250 VAC / DC ± 10%	
RS 485 & 4-20 mA Analnog Output	RS 485 & 4-20 mA included in Model Amik 301.	

## Accessories – Three-Phase Current Transformer

A three-phase terminal style current transformer can be used with AMIK three phase meters. Other CT'S available

The current transformer is equipped with terminals to permit easy connection to the AMIK units.

These terminals are #8-32 brass studs and come with a flatwasher, lockwasher and a regular nut (leads are not provided).



### Ordering Information

Catalog Number	Current Ratio	Accuracy @ 60 Hz	Burden VA @ 60 Hz
37026	50:5	± 3%	2.0
37027	100:5	± 2%	2.0
37028	150:5	± 1%	4.0
37029	200:5	± 1%	5.0
37030	300:5	± 1%	10.0

**Simpson**<sup>®</sup>